

---

## **HIDDEN FASTENING SYSTEM WITH CAPS FOR P500 AND P700**

---

Parklex offers caps in the same finish as the Parklex 500 and Parklex 700 panels for hidden fastening using caps measuring 10.75mm in diameter.

### **BASIC PRINCIPLES FOR INSTALLING P500 and P700**

#### **1. Ventilated chamber**

Parklex 500 panels must be separated from the wall face by battens that have been installed vertically, forming a chamber measuring at least 20mm.

In the event that some type of insulation will be installed, a double batten structure or a single batten structure with adjustable support bases must be installed, ensuring that the chamber is maintained.

To permit air circulation in the ventilated chamber, the air intake and output must be adequately proportioned.

##### **1.1. Base ventilation**

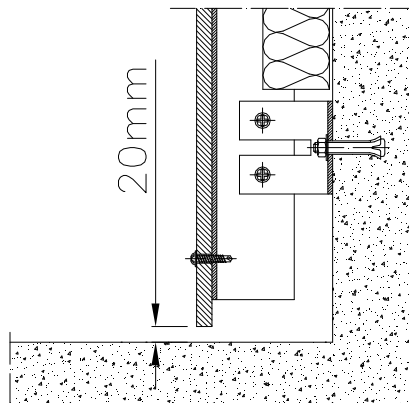

##### **1.2. Crown ventilation**

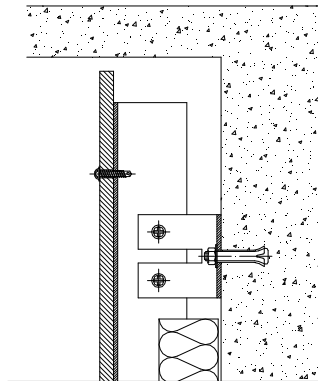

## 2. Expansion joints

It is necessary to leave peripheral expansion joints between the panels and in places where they meet with other faces so they may absorb any expansion movements.

The thickness of these joints depends on the panel dimensions and aesthetics.

As an example, for panels measuring 2.44 x 1.22 m, these joints must be at least 5 or 6mm, although it is recommended to leave 10mm joints whenever possible.

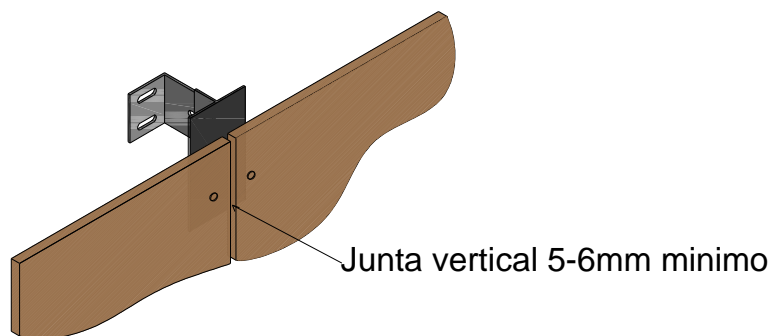

It is recommended not to seal the joints with putty, since this may lead to an accumulation of dirt around the edges of the panels.

## 3. Panel movement

Parklex panels are made from natural wood.

Wood is a living material that undergoes dimensional changes due to changes in humidity and temperature.

Therefore, it is important for the fasteners to allow panel movement, permitting their free expansion and contraction.

## 4. Choosing panel thickness

The panel thickness is selected according to the face being covered (walls, false ceilings and outdoor awnings).

The thickness of the panel influences the distance between the support battens; the greater the thickness, the greater the distance between the battens.

## 5. Substructure: wood or metal

To facilitate air circulation behind the panels, a substructure of vertical battens must be installed.

The substructure must be proportioned in such a way that it meets all the stationary requirements. Likewise, keep in mind the inclination of the façade, the fastening system chosen, the thickness and the dimensions of the Parklex panel being installed. In addition, it must be well protected against corrosion and rotting, regardless of the material or system used.

### 5.1. Type of batten

- Wood substructure:

When installing interior panels, wood battens are most commonly used.

- **Metal substructure:**  
As with façade panels, metal battens, such as those made from galvanized steel or aluminium may be used.

## 6. Three support points

Parklex 500 and Parklex 700 panels must be supported by at least three points of support.

The distances between support points depend on the type of fasteners and the thickness of the material. The instructions regarding distances that appear in the chapter “Installation types” may be followed, as long as there are at least three points of support in each direction.

## HIDDEN FASTENING SYSTEM WITH CAPS FOR P500 AND P700

When fastening using caps, all the recommendations indicated for exposed fasteners, such as screws and rivets, must be followed.

The only difference is in the screw being used. In this case, the screw must have a head that is smaller than the diameter of the hole, so that panel movement is permitted.

The minimum recommended panel thickness for fastening with caps is 11mm.

