

EXPOSED FASTENING SYSTEM WITH SCREWS OR RIVETS

Parklex 500 panels for interiors may be installed using mechanical fasteners, such as screws or rivets.

The panels are attached to vertical battens.

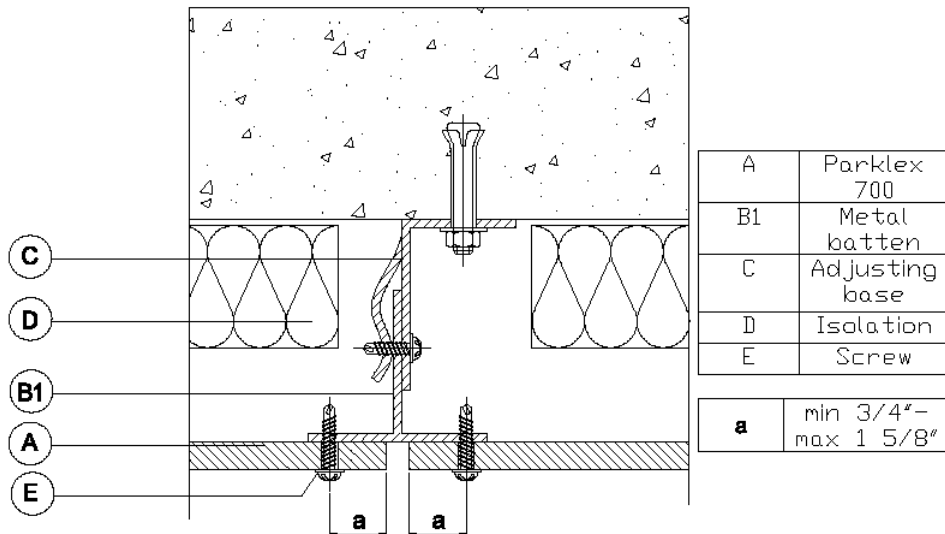

In the event that the wall is not perfectly vertically aligned, support bases may be used to regulate the height of the batten installation.

BASIC PRINCIPLES FOR INSTALLING P500 and P700

1. Ventilated chamber

Parklex 500 panels must be separated from the wall face by battens that have been installed vertically, forming a chamber measuring at least 3/4".

In the event that some type of insulation will be installed, a double batten structure or a single batten structure with adjustable support bases must be installed, ensuring that the chamber is maintained.

To permit air circulation in the ventilated chamber, the air intake and output must be adequately proportioned.

1.1. Base ventilation

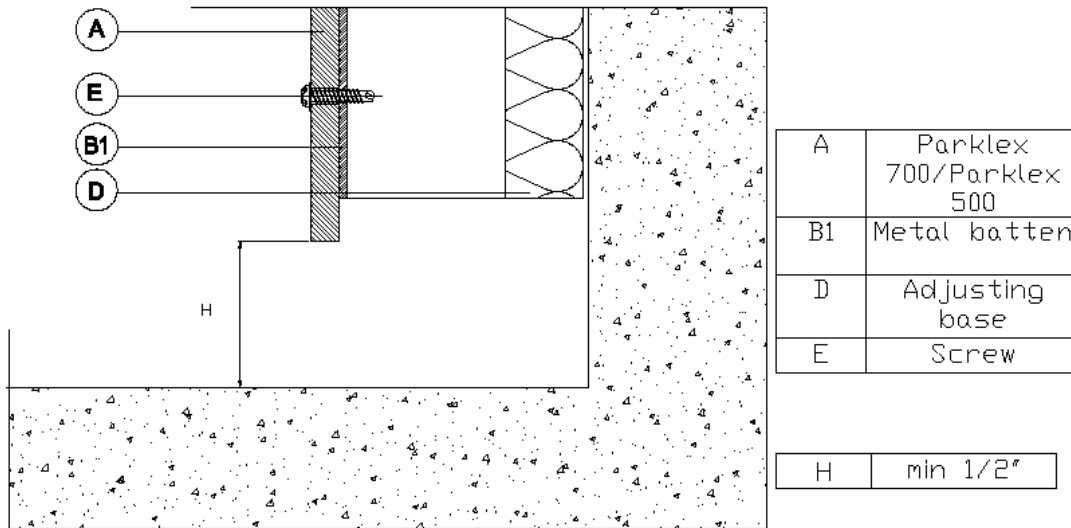

1.2. Crown ventilation

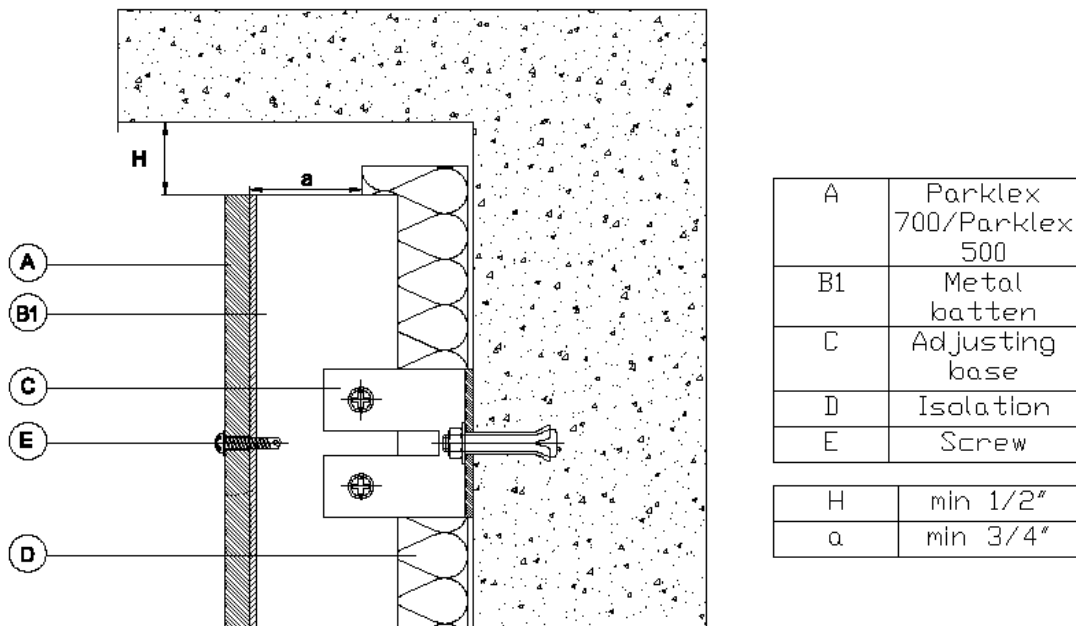

2. Expansion joints

It is necessary to leave peripheral expansion joints between the panels and in places where they meet with other faces so they may absorb any expansion movements.

The thickness of these joints depends on the panel dimensions and aesthetics.

As an example, for panels measuring 96" x 48", these joints must be at least 3/16" or 1/4", although it is recommended to leave 3/8" joints whenever possible.

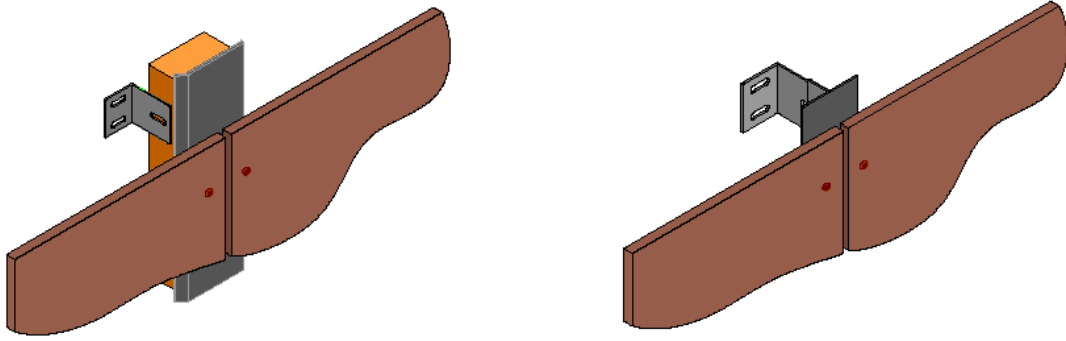

It is recommended not to seal the joints with putty, since this may lead to an accumulation of dirt around the edges of the panels.

3. Panel movement

Parklex panels are made from natural wood. Wood is a living material that undergoes dimensional changes due to changes in humidity and temperature.

Therefore, it is important for the fasteners to allow panel movement, permitting their free expansion and contraction.

4. Choosing panel thickness

The panel thickness is selected according to the face being covered (walls, false ceilings and outdoor awnings).

The thickness of the panel influences the distance between the support battens; the greater the thickness, the greater the distance between the battens.

5. Substructure: wood or metal

To facilitate air circulation behind the panels, a substructure of vertical battens must be installed.

The substructure must be proportioned in such a way that it meets all the stationary requirements. Likewise, keep in mind the inclination of the façade, the fastening system chosen, the thickness and the dimensions of the Parklex panel being installed. In addition, it must be well protected against corrosion and rotting, regardless of the material or system used.

5.1. Type of batten

- Wood substructure:
When installing interior panels, wood battens are most commonly used.
- Metal substructure:
As with façade panels, metal battens, such as those made from galvanized steel or aluminium may be used.

6. Three support points

Parklex 500 and Parklex 700 panels must be supported by at least three points of support.

The distances between support points depend on the type of fasteners and the thickness of the material. The instructions regarding distances that appear in the chapter “Installation types” may be followed, as long as there are at least three points of support in each direction.

FASTENERS

Distance between battens:

Thickness	Distance
5/16"	24"
≥7/16"	32"

* as long as there are at least 3 fastening points.

Distance between fasteners:

Thickness	Distance
5/16"	24"
≥7/16"	32"

Drilling the holes:

Parklex 700 panels undergo dimensional variations due to temperature and humidity. These dimensional variations and variations in the structure must be taken into account when drilling the holes.

If using screws, the diameter of the hole must be 1/16"-1/8" larger than the diameter of the screw shank, except at one point per panel where it must be equal to it. This fixed point must be as close as possible to the geometric centre of the panel. Bevel-headed screws must NEVER be used because they prevent panel movement as the result of dimensional changes.

If using rivets, the diameter of the hole must be 1/8" larger than the diameter of the rivet shank, except at one point per panel where it must be equal to it. This fixed point must be as close as possible to the geometric center of the panel.

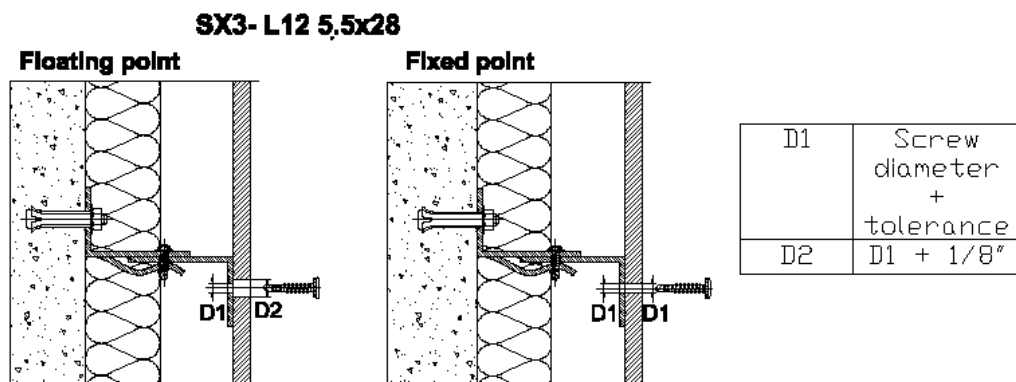

AP16 5x16, 21

Floating point

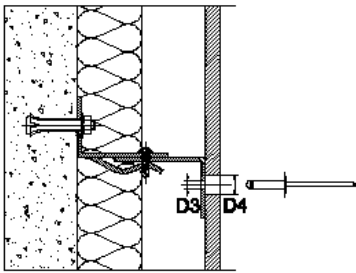

Fixed point

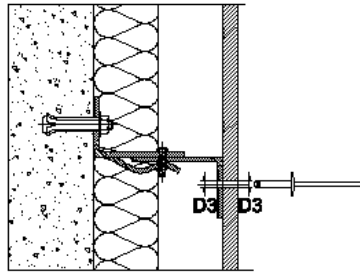

D3	Rivet diameter + tolerance
D4	D3 + 1/8"

TWS D12 4,8xL

Floating point

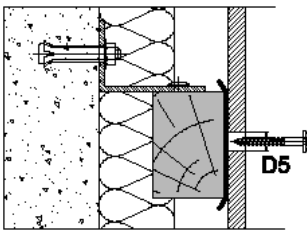

Fixed point

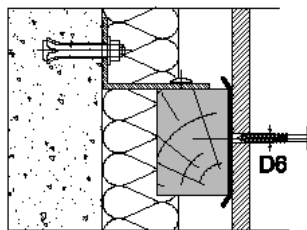

D5	Screw diameter + tolerance
D6	D5 + 1/8"

Fastening distance from the edges:

